

ACT 471SEL Selenium Hybrid Filter Device

A Full-Featured Primary Surge Protection/Filter Device



▶ Power quality is more important today than ever before and that means not just any surge protector can be relied on to protect your facility properly. The ACT 471 SEL Family is designed to protect all phases and modes against transient surges and limited over voltage events and, with the Advanced Power Filter selected, is able to reduce induced high frequency noise by over 50 dB across a broad frequency spectrum.

Unlike many of our competitors, the ACT hybrid design comes standard with many different alarm options. Add our Power Quality Meter option and no other company can provide this level of Power Quality Diagnostic information. "Transient Snap Shot" and "Time Stamp Data Logger" are included.

No other protection company is offering this breadth of power filtering and monitoring capability in a single package.

▶ RECOMMENDED LOCATION

- Building Entrance / Cat C
- Primary Surge Protection for a Facility
- Switch Gear
- Motor Control Center

▶ FEATURES AND BENEFITS

- Listed Type 1 and Type 2
- 200 kAIC rated Fuse or Optional Fused Disconnect
- Up to 300,000 amps per mode modular protection (600,000 per Phase)
- **BEST IN CLASS** built in Filter options in the market >55dB
 - Advanced filter targets most common transient surges and damaging medium frequency noises
- Copper Bus Connected Surge Modules
- 10 Modes of Protection (L-N, L-G, N-G, L-L)
 - 7 Modes Discrete (L-N, L-G, N-G)
- Dual Surge Counter Options (Continuous and Resettable)
- Microprocessor-Based PQ Meter
- Smart Monitoring
 - Diagnostic board not only tells you Good & Bad Phase protection but also what module needs replaced
 - Selenium Over Voltage Filter is individually monitored
- NO / NC Form C Dry Contacts
 - For remote monitoring & control (250V 5 A rating)
 - Individual Remote Monitoring of both MOV and Selenium Rectifiers
- Individually Fused and Protected MOV Technology
- NEMA 4 & NEMA 12 Painted Steel Enclosure
- 20 Year Standard Warranty – Options with extended warranty card

MOST ADVANCED MONITORING SYSTEM ON THE MARKET

- Lights (LED) – Green per Phase, Red - Alarm
- Audible Alarms – STANDARD
- Dual Relays – STANDARD NO / NC Form C Dry Contacts
- Dual Surge Counters (optional)
- Full Microprocessor-Based Power Quality Meter (optional)
- Logging Capability (optional)
- Event Waveform Capture (optional)

▶ STANDARDS MET

- Listed to UL 1449 4th edition March 2016
- Power Filtering – UL 1283
- ANSI/NFPA 70 National Electrical Code
- NEMA LS 1-1992

▶ 3RD PARTY TESTED

- ACT 471 is tested in all modes at rated currents by independent testing facilities
- Repetitive surge testing per IEEE C62.41.2 C3 combination without any degradation of more than 10% deviation. Greater than 20,000 impulses*

ACT 471SEL Selenium Hybrid Filter Device

A Full-Featured Primary Surge Protection/Filter Device



ACT 471-277Y-270-SEL-D-F2

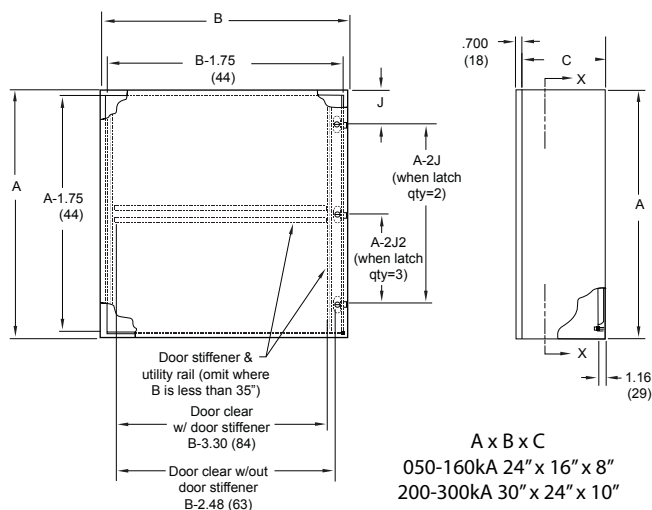

*Full mechanical drawings available upon request.

TECHNICAL INFORMATION

MECHANICAL SPECIFICATIONS

Dimensions	050, 100, 160 – 24x16x8 (in) 200, 270, 300 – 30x24x10 (in)
Weight (determined by option)	Up to 110 lbs.
Enclosure	NEMA 12/4 Painted Steel
Operating Temp	-40°F to +140°F -40°C to +65°C
Non-condensing Humidity	5% to 95%

ELECTRICAL SPECIFICATIONS

UL Type 1	with fused disconnect option
Connection Method	Parallel
Protection Modes	All Modes (L-N, L-G, N-G, L-L)
Wired Lugs	Up to 2 AWG
Status Indicators	Working - Green LED's Alarm - Red LED
Dual Alarm Relay Contacts	Form C NC & NO
Audible Alarm	Turn On/Off Switch
Dual Surge Counters	Continuous & Resettable
Filter (3kHz – 10MHz)	>-50dB

Part Number	Configuration	MCOV	VPR (Voltage Protection Rating) – IEEE C62 UL 1449 4th Edition			
			L-N	L-G	N-G	L-L
471-120S-XXX-SEL-YY	120/240 Vac 3W+G	150V	700	700	700	1000
471-120Y-XXX-SEL-YY	120/208 Vac 4W+G	150V	700	700	700	1000
471-277Y-XXX-SEL-YY	277/480 Vac 4W+G	320V	1000	1000	1000	1800
471-240D-XXX-SEL-YY	240 Vac 3W+G, delta	320V	-	1000	-	1800
471-240H-XXX-SEL-YY	120/240 Vac 4W+G, delta HL PHB	150V/320V	700/1000	700/1000	1000	1000/1800
471-480D-XXX-SEL-YY	480 Vac 3W+G, delta	600V	-	1800	-	3000

EXAMPLE: ACT 471-277Y-160-SEL-D-F-C2-M2

Industrial Series SPD, 277/480 Vac 4W+G, 160 kA/ Mode, Modular Selenium Hybrid Filter/Protector at 160kA/Mode, Internal Disconnect, EMI/Noise Filter, 2 Surge Counters, V2 option on the Power Quality Meter

OPTIONS:

XXX	Surge Rating (kA) by Mode:	050, 080, 100, 125, 160, 200, 270 or 300
SEL		Modular Selenium Hybrid Filter/Protector
YY	Enclosure Type:	NEMA 12/4 (STANDARD) Aluminum - ALM Stainless Steel - SS
	Internal Disconnect:	600V 100 Amp Quick Fuse- D
	Filter(s):	EMI/Noise Filter - F Advanced EMI/Noise Filter - FA1 or FA2
	Counter(s):	Surge Counter - C1 or C2 Continuous or Resettable
	Microprocessor-based PQ Meter:	M 2-6 number refers to V option (See ACT M200 specification sheet)

ACT 471SEL Selenium Hybrid Filter Device

A Full-Featured Primary Surge Protection/Filter Device

▶ PRODUCT SURGE TEST DATA

Voltage Configuration	Protection Mode	MCOV	A1 Ring Wave	B3 Ring Wave	B3/C1 Combo	C3 Combo	UL1449 4th edition
			2kV/67A	6kV/500A	6kV/3kA	20kV/10kA	6kV/ 3kA
1P 240V	L-N	320V	46.7	460	932V	1100V	1000 V
	L-G	320V	46.5	472	950V	1200V	1000 V
	N-G	320V	52	468	950V	1150V	1000 V
120/240	L-N	150V	46	460	528V	1000V	700V
	L-G	150V	46.5	472	534V	1050V	700V
	N-G	150V	52	468	580V	1075V	700V
120/240 with 240V High Leg	L-N	150V	46	460	528V	1000V	700V
	L-N High	320V	46.7	547	932V	1100V	1000 V
	N-G	150V	52	468	580V	1075V	700V
120/208	L-N	150V	46	460	528V	1000V	700V
	L-G	150V	46.5	472	534V	1050V	700V
	N-G	150V	52	468	580V	1075V	700V
220/380	L-N	320V	46.7	547	932V	1100V	1000 V
	L-G	320V	47.2	520	950V	1200V	1000 V
	N-G	320V	53	560	950V	1150V	1000 V
277/480	L-N	320V	46.7	547	932V	1100V	1000 V
	L-G	320V	46.5	520	950V	1200V	1000 V
	N-G	320V	52	560	950V	1150V	1000 V
240D	L-G	320V	58	547	950V	1105V	1000 V
	L-L	640V	64	1100	1820V	2390V	1800V
380D	L-G	550V	58	1058	1741V	1924V	1800V
	L-L	1100V	82	2100	2331V	3250V	2500V
480D	L-G	550V	58	1058	1741V	1924V	1800V
	L-L	1100V	82	2100	2331V	3250V	2500V

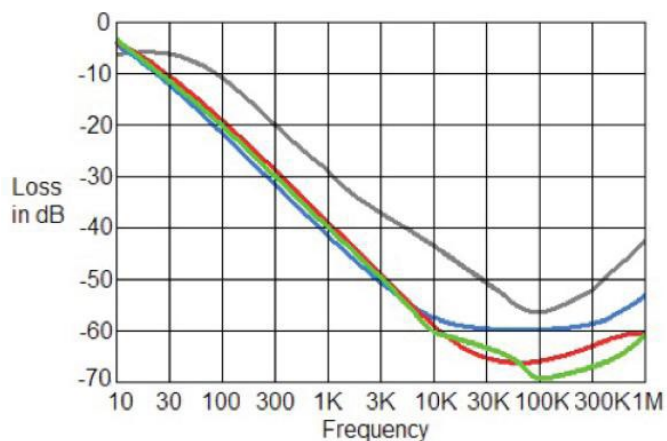

ACT's Advanced Power Filter system is designed to filter frequencies between 3 kHz to 1 Mhz using a broad spectrum band reject filter that out performs most SPD EMI filters on the market. NEMA LS-1 requires evidence of band rejection across a stated spectrum, be sure your EMI filter specification leaves no frequency holes.

***Red & Green lines represent the Advanced Filter Option when compared to leading filter manufacturers.**

*Tests were conducted with Power Filters installed

ACT 471SEL Selenium Hybrid Filter Device

A Full-Featured Primary Surge Protection/Filter Device

COMMON ELECTRICAL APPLICATIONS

Single Phase, 3-Wire (with Neutral)

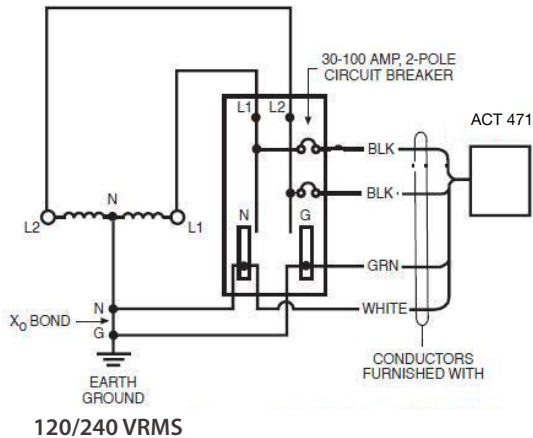

3-Phase, 4-Wire WYE

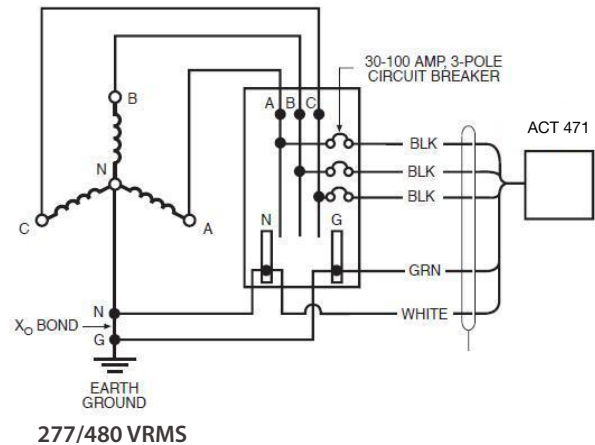

3-Phase, 3-Wire +Ground DELTA

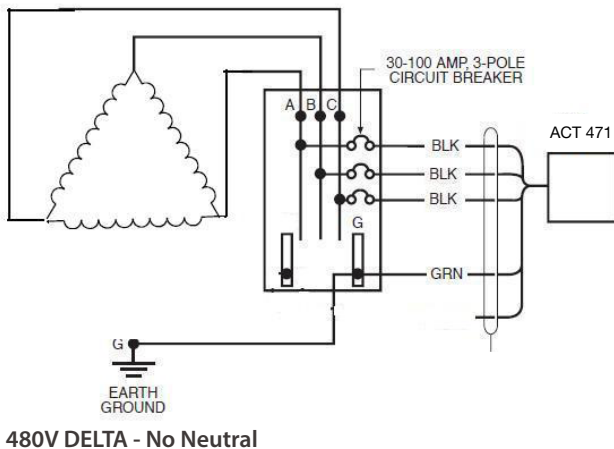

CAUTION:

It is extremely important to know the true voltage on any power panel that a Surge Protection Device is being specified for. If Electrical 1 – Lines do not exist, then it is important for an electrician to verify if the power panel to be protected is 277/480V 4W+G versus 480V 3W+G. While both products look similar, they will only operate correctly if installed in its intended voltage application. Placing any SPD on a 480V Delta system that is not designed for it can cause serious damage to both power filters and SPD devices.