

ACT 482 2U Rack Mounted AC Load Panel

Power Distribution Panel



▶ In today's applications, rack mounted power distribution panels must be flexible to handle the many changing customer needs. The ACT 482-120S-3103-500 19" - 2U Power Distribution Panels offer a wide range of options to allow specific customization at off the shelf pricing. Optional features include molded Plexi glass safety hood.

▶ RECOMMENDED LOCATION

- Telecom Cabinets
- Waste Water Treatment Cabinets
- Remote Shelters or Cabinets

▶ FEATURES AND BENEFITS

- 120 /240V Split Phase Panel
- 1- 15 Amp Breaker to GFI outlet option allows technicians an easy access point for power
- 2-30 Amp Breaker that can be used individually for 120V or ganged to trip 240V together
- Square D QOU type quality breakers
- Finished Aluminum – light weight while providing strength
- 2 -Year Standard Warranty

▶ STANDARDS MET

- Safety – Panel Designed to UL 67
- Breakers – UL 489 Listed – CSA
- 22.2 #5.1
- IEEE 1100
- ANSI/IEEE C62.41, C62.45
- ANSI/NFPA 70 National Electrical Code

▶ SPECIFICATIONS

MECHANICAL

Dimensions: 19" x 3.468" x 5.0"
Weight: 4.5 lbs
Operating Temp: -40F to 140F
Non-condensing humidity: 5% to 95%

ELECTRICAL

Wire Size: #14 - 2 Awg
Number of poles/breakers: 1-Pole
Short Circuit Current Rating: 10kA@120/240 VAC
Breaker Type: Square D QOU
Approval on Breakers: UL 489 Listed, CSA 22.2 #5.1 Certified

Ampere Rating: 30, 20, 15 Amp
Cord Connections: All cords and connectors specifications are considered custom and must be specified by the customer in writing.

▶ PART NUMBER DESCRIPTION

ACT 482	2U Rack Mounting	
UUU	120	Single Phase
	120S	120/240 Split Phase
	120Y	120/208 Three Phase
V	1-6	Number of Breakers
W	0	No GFI
	1	Internal GFCI
	2	External GFCI
XX	00 - 99	Custom Options
Y	N	No Surge Protection Device
	S	40kA Surge Protection Device
ZZ	00 - 99	Custom Options

Note: ZZ = 01 for Plexiglass Safety Shield

ACT 482 2U Rack Mounted AC Load Panel

ACT 482-120S-3101-S00

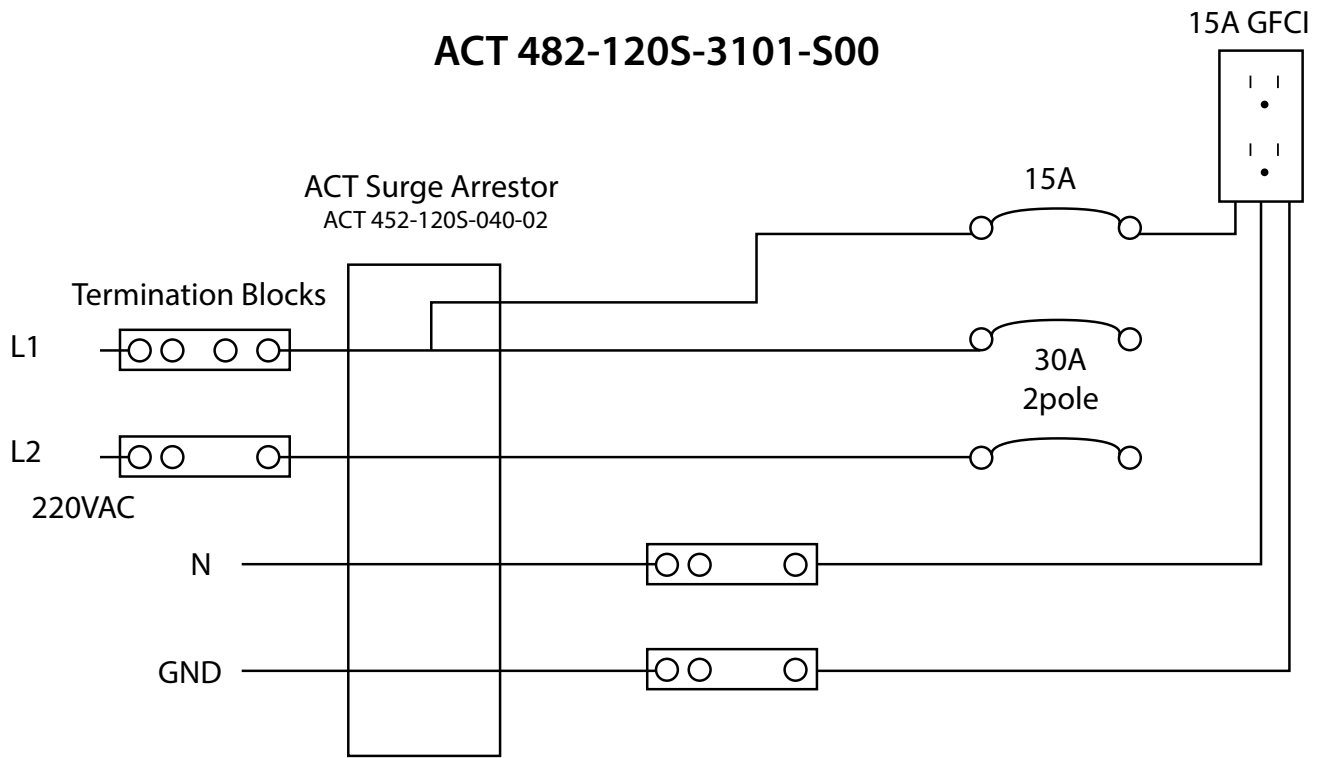

RWG 06/18/2012